



SJ 12 | SJ 16

SELF PROPELLED VERTICAL MAST LIFTS

Skyjack's SJ 12 and SJ 16 self propelled vertical mast lifts provide a compact footprint and superior maneuverability. When operating in tight workspaces, a high degree steer angle allows for superior functionality and flexibility by offering zero inside turning radius. Both models feature a 20" (0.51m) traversing platform, providing increased access and the ability to reach over potential obstacles. A unique slide away platform provides easy access to components, when raised or in the stowed position.

Skyjack's standard color coded and numbered wiring system with hard-wired relay based controls help to ensure both the SJ 12 and SJ 16 live up to Skyjack's reputation for quality and serviceability.



SKYJACK

SELF PROPELLED VERTICAL MAST LIFTS

Specifications	SJ 12	SJ 16
A Work Height	18' (5.48 m)	21'7" (6.58 m)
B Raised Platform Height	12' (3.65 m)	15'7" (4.75 m)
C Lowered Platform Height	18" (0.45 m)	18" (0.45 m)
D Overall Width	30" (0.76 m)	30" (0.76 m)
E Overall Length	54" (1.37 m)	54" (1.37 m)
F Stowed Height	70" (1.79 m)	70" (1.79 m)
G Platform Width (Inside Dimension)	27" (0.69 m)	27" (0.69 m)
H Platform Length (Inside Dimension)	37" (0.93 m)	37" (0.93 m)
Ground Clearance (Stowed)	2.1" (5.33 cm)	2.1" (5.33 cm)
Ground Clearance (Elevated)	0.63" (1.60 cm)	0.63" (1.60 cm)
Wheelbase	42" (1.05 m)	42" (1.05 m)
Weight	1,720 lbs (782 kg)	2,130 lbs (966 kg)
Local Floor Load (with rated load)	101 psi (696 kPa)	120 psi (827 kPa)
Local Floor Load (no load)	80 psi (552 kPa)	92 psi (634 kPa)
Gradeability	30%	30%
Turning Radius (Inside)	0	0
Turning Radius (Outside)	55" (1.40 m)	55" (1.40 m)
Lift Time (With Rated Load)	16 seconds	18 seconds
Drive Speed (Stowed)	2.5 mph (4.0 km/h)	2.5 mph (4.0 km/h)
Drive Speed (Raised)	0.5 mph (0.8 km/h)	0.5 mph (0.8 km/h)
Maximum Drive Height	Full Height	Full Height
Capacity (Overall)	500 lbs (227 kg)	500 lbs (227 kg)

Maximum # of Persons

2

2

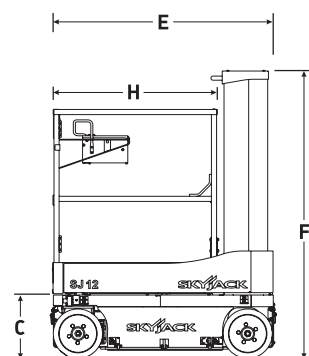
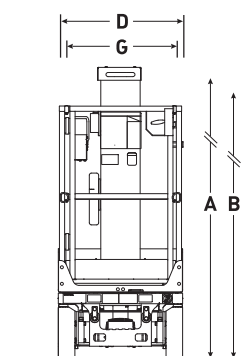

STANDARD FEATURES

- Drivable at full height
- Variable speed, front two wheel hydraulic drive
- Zero inside turning radius
- Dual holding brakes
- Proportional controls
- 20" (0.51 m) Traversing platform
- 24V DC power source
- Low voltage battery protection
- 30% gradeability
- Solid rubber, non-marking tires
- Pothole protection system
- 110V AC outlet at platform with GFI
- 28 mph (12.5 m/s) wind rating
- Tilt alarm with drive & lift cut-out
- All motion audible alarm
- Lanyard attachment points
- Operator horn
- Lift rings/tie downs
- Chain entrance
- Relay based control system
- Color coded and numbered wiring system

OPTIONS*

- Dual flashing light
- AC inverter
- Half height spring hinged gate
- Full height spring hinged gate
- Saloon gate
- Light duty pipe rack/steel stud rack
- Tool tray
- Florescent tube carrier
- Bio Oil

* Capacities, and machine weights may differ when options are added.

Skyjack Head Office

55 Campbell Rd. Guelph, ON Canada N1H 1B9
 Sales Inquiries: 1-877-755-4387 (1-877-SJLIFTS)
 Main Switchboard: 1-800-265-2738
 Phone: 519-837-0888
 Fax: 519-837-8104
 Email: skyjack@skyjack.com

www.skyjack.com



SKYJACK™

This brochure is for illustrative purpose only and based on the latest information at the time of printing. Skyjack Inc. reserves the right to make changes at any time, without notice, to specifications, standard and optional equipment. Consult the Operating Maintenance and Parts Manuals for proper procedures. Work platforms have been tested to comply with ANSI and CSA standards as interpreted by Skyjack, Inc.