



Cat[®] 272D2 XHP

SKID STEER LOADER

FEATURES:

The Cat[®] 272D2 XHP Skid Steer Loader, with its powerful engine, high output hydraulic system, high lift forces and vertical lift design, provides the maximum performance for work tool productivity, digging, truck loading and material handling. The 272D2 XHP features the following:

- **Industry leading sealed and pressurized cab option** provides a cleaner and quieter operating environment with excellent work tool visibility.
- **Standard high-back, heated, air ride seat with seat mounted adjustable joystick controls** makes Cat Skid Steer Loaders the industry leader in operator comfort.
- **High performance power train** provides maximum performance and production capability through the Electronic Torque Management system, standard two speed travel and an electronic hand/foot throttle with decel pedal capability.
- **XHP hydraulic system** provides high flow and high pressure that delivers industry leading hydraulic horsepower to efficiently run even the most power hungry work tools.
- **Electronically controlled Cat C3.8 engine** provides high horsepower and torque while meeting U.S. EPA Tier 4 Final/EU Stage IV emission standards.
- **Cat "Intelligent Leveling" system (ILEV)** provides industry leading technology, integration and features such as dual direction self level, work tool return to dig and work tool positioner.
- **Standard Speed Sensitive Ride Control system** improves operation on rough terrain, enabling better load retention, increased productivity and greater operator comfort.
- **Maximize machine capability and control** with the standard Advanced Display providing on-screen adjustments for implement response, hystat response and creep control. Also features multi-language functionality with customizable layouts, security system and rearview camera.
- **Ground level access** to all daily service and routine maintenance points helps reduce machine downtime for greater productivity.
- **Broad range of performance matched Cat Work Tools** make the Cat Skid Steer Loader the most versatile machine on the job site.

Specifications

Engine

Engine Model	Cat C3.8 DIT (turbo)	
Gross Power SAE J1995	82 kW	110 hp
Net Power SAE 1349	79 kW	106 hp
Net Power ISO 9249	80 kW	107 hp
Peak Torque at 1,500 rpm SAE J1995	374 N-m	276 lbf-ft
Displacement	3.8 L	232 in ³
Stroke	120 mm	4.7 in
Bore	100 mm	3.9 in

Weights*

Operating Weight	4198 kg	9,255 lb
------------------	---------	----------

Power Train

Travel Speed (Forward or Reverse):		
One Speed	11.6 km/h	7.2 mph
Two Speed	16.6 km/h	10.3 mph

Operating Specifications*

Rated Operating Capacity	1656 kg	3,650 lb
Rated Operating Capacity with Optional Counterweight	1769 kg	3,900 lb
Tipping Load	3311 kg	7,300 lb
Breakout Force, Tilt Cylinder	3339 kg	7,362 lb
Breakout Force, Lift Cylinder	2760 kg	6,085 lb

Hydraulic System

Hydraulic Flow – XHP:		
Maximum Loader Hydraulic Pressure	28 000 kPa	4,061 psi
Maximum Loader Hydraulic Flow†	150 L/min	40 gal/min
Hydraulic Power (calculated)	70 kW	94 hp
Standard Flow Mode:		
Loader Hydraulic Pressure	23 000 kPa	3,335 psi
Loader Hydraulic Flow	86 L/min	23 gal/min
Hydraulic Power (calculated)	33 kW	44 hp

†When equipped with Cat 400 Series work tools.

Cab

ROPS	ISO 3471:2008
FOPS	ISO 3449:2005 Level I
FOPS Level II	ISO 3449:2005 Level II

Service Refill Capacities

Chain Box, each side	10.2 L	2.7 gal
Cooling System	16 L	4.1 gal
Diesel Exhaust Fluid (DEF) Tank	19 L	5 gal
Engine Crankcase	13 L	3.5 gal
Fuel Tank	122 L	32.2 gal
Hydraulic System	55 L	14.5 gal
Hydraulic Tank	39 L	10.3 gal



272D2 XHP Skid Steer Loader

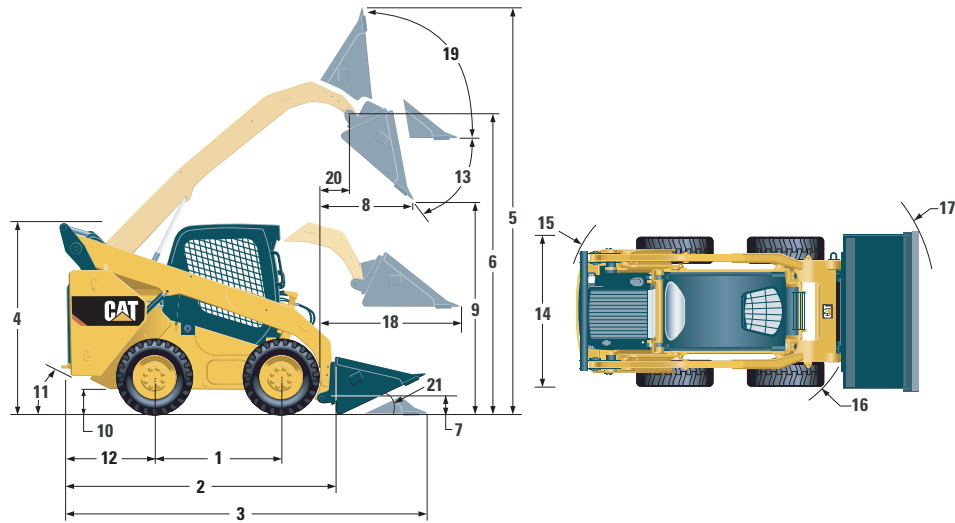

Dimensions*

1	Wheelbase	1386 mm	54.6 in
2	Length without Bucket	3226 mm	127.0 in
3	Length with Bucket on Ground	3937 mm	155.0 in
4	Height to Top of Cab	2133 mm	84.0 in
5	Maximum Overall Height	4103 mm	161.5 in
6	Bucket Pin Height at Maximum Lift	3265 mm	128.6 in
7	Bucket Pin Height at Carry Position	235 mm	9.3 in
8	Reach at Maximum Lift and Dump	736 mm	29.0 in
9	Clearance at Maximum Lift and Dump	2474 mm	97.4 in
10	Ground Clearance	263 mm	10.4 in
11	Departure Angle		28°
12	Bumper Overhang behind Rear Axle	1175 mm	46.2 in
13	Maximum Dump Angle		51°
14	Vehicle Width over Tires	1930 mm	76.0 in
15	Turning Radius from Center – Machine Rear	1899 mm	74.7 in
16	Turning Radius from Center – Coupler	1466 mm	57.7 in
17	Turning Radius from Center – Bucket (racked)	2301 mm	90.6 in
18	Maximum Reach with Arms Parallel to Ground	1246 mm	49.1 in
19	Rack Back Angle at Maximum Height		84°
20	Bucket Pin Reach at Maximum Lift	344 mm	13.5 in
21	Roll Back Angle		28°

*Operating Weight, Operating Specifications and Dimensions all based on 75 kg (165 lb) operator, all fluids, two speed, ride control, enclosed cab with glass door, side windows, air conditioning, air ride seat, advanced display, rearview camera, 1,000 CCA battery, dual direction self level, 1981 mm (78 in) dirt bucket, no optional counterweights, Cat PC 14 x 17.5 tires and manual quick coupler (unless otherwise noted).

Noise Level

Inside Cab**	83 dB(A)
Outside Cab***	104 dB(A)

- Cab and Rollover Protective Structures (ROPS) are standard in North America and Europe.

**The declared dynamic operator sound pressure levels per ISO 6396:2008. The measurements were conducted with the cab doors and windows closed and at 70% of the maximum engine cooling fan speed. The sound level may vary at different engine cooling fan speeds.

***The labeled sound power level for the CE marked configurations when measured according to the test procedure and conditions specified in 2000/14/EC.

Air Conditioning System

The air conditioning system on this machine contains the fluorinated greenhouse gas refrigerant R134a (Global Warming Potential = 1430). The system contains 0.81 kg of refrigerant which has a CO₂ equivalent of 1.158 metric tonnes.

MANDATORY EQUIPMENT

- Quick Coupler, Mechanical or Powered
- Seat Belt, 50 mm (2 in) or 75 mm (3 in)

PERFORMANCE PACKAGE

- Performance Package H3: *XHP Hydraulics, Dual Direction Electronic Self Level (Raise and Lower), Work Tool Return to Dig, Work Tool Positioner, Electronic Snubbing (Raise and Lower)*

STANDARD EQUIPMENT

ELECTRICAL

- 12 volt Electrical System
- 100 ampere Alternator
- Ignition Key Start/Stop Switch
- Lights: *Gauge Backlighting, Two Rear Tail Lights, Two Rear Halogen Working Lights, Two Adjustable Front Halogen Lights, Dome Light*
- Backup Alarm
- Heavy Duty Battery, 1,000 CCA, with Battery Disconnect

OPERATOR ENVIRONMENT

- Gauges: *Fuel Level, DEF Level, Hour Meter*
- Operator Warning System Indicators: *Air Filter Restriction, Alternator Output, Armrest Raised/Operator Out of Seat, Engine Coolant Temperature, Engine Oil Pressure, Air Inlet Heater Activation, Hydraulic Filter Restriction, Hydraulic Oil Temperature, Park Brake Engaged, Engine Emission System*
- High Back Cloth Seat with Air Suspension, Heated with Recline and Lumbar Support and Fully Adjustable Seat Mounted Controls
- Fold In Ergonomic Contoured Armrest
- Control Interlock System, when operator leaves seat or armrest raised: *Hydraulic System Disables, Hydrostatic Transmission Disables, Parking Brake Engages*
- ROPS Cab, Enclosed, Tilt Up
- FOPS, Level I
- Top, Rear and Side Windows
- Headliner, Deluxe
- Floor Mat
- Interior Rearview Mirror
- 12 volt Electric Socket
- Horn
- Hand (Dial) and Foot Throttle, Electronic with Decel Feature
- Advanced Display: *Full Color, 127 mm (5 in) LCD Screen, Advanced Multi-operator Security System, On-screen Adjustments for Implement Response, Hystat Drive Response, and Creep Control; Rearview Camera Included*
- Storage Compartment with Netting

OPTIONAL ATTACHMENTS

- Beacon, Rotating
- Engine Block Heater – 120V
- Oil, Hydraulic, Cold Operation
- Paint, Custom
- Variable Speed Demand Fan with Reversing Functionality

COMFORT PACKAGE

- Enclosed ROPS with A/C (C3): *Foot Throttle, Headliner, Heater and Defroster, Side Windows, Cup Holder, Radio Ready, Air Ride Seat (High Back and Heated) and Door (Glass or Polycarbonate)*

POWER TRAIN

- Cat C3.8, Turbo Diesel Engine, Meeting Tier 4 Final/Stage IV Emission Standards
- Air Cleaner, Dual Element, Radial Seal
- S-O-SSM Sampling Valve, Hydraulic Oil
- Filters, Cartridge-type, Hydraulic
- Filters, Cartridge-type, Fuel and Water Separator
- Radiator/Hydraulic Oil Cooler (side-by-side)
- Spring Applied, Hydraulically Released Parking Brakes
- Hydrostatic Transmission, Two Speed with Speed Sensitive Ride Control
- Four Wheel Chain Drive, 14 × 17.5 Tires

OTHER

- Engine Enclosure, Lockable
- Extended Life Antifreeze, –37° C (–34° F)
- Machine Tie Down Points (6)
- Support, Lift Arm
- Hydraulic Oil Level Sight Gauge
- Radiator Coolant Level Sight Gauge
- Radiator, Expansion Bottle
- Cat ToughGuard™ Hose
- Auxiliary, Hydraulics, Continuous Flow
- Heavy Duty, Flat Faced Quick Disconnects with Integrated Pressure Release
- Split D-Ring to Route Work Tool Hoses Along Side of Left Lift Arm
- Electrical Outlet, Beacon
- Belly Pan Cleanout
- Variable Speed Demand Fan
- Product Link™ PL240, Cellular

- External Counterweights
- Product Link PL641, Cellular
- Bluetooth Radio with Microphone (AM/FM/Weather Band Receiver with USB and Auxiliary Input Jack)

272D2 XHP Skid Steer Loader

For more complete information on Cat products, dealer services, and industry solutions, visit us on the web at www.cat.com

© 2017 Caterpillar
All rights reserved

Materials and specifications are subject to change without notice. Featured machines in photos may include additional equipment. See your Cat dealer for available options.

CAT, CATERPILLAR, SAFETY.CAT.COM, their respective logos, "Caterpillar Yellow" and the "Power Edge" trade dress, as well as corporate and product identity used herein, are trademarks of Caterpillar and may not be used without permission.

AEHQ7439-01 (03-2017)
Replaces AEHQ7439
(NACD, EU, ANZ)

